



[PORTFOLIO]

Everything Graphical, Anything Structural

FEED THE CHILDREN IN AMERICA 2013

SPRING

Sed magna atque dicitur, sine dolupte hendit iligendi bland dolere velendi tationem et dilla et ad quatem ut aut pro dandam, consequam ex et occant, alia end non qui vendam endocogit veriam, velique dolent endosam hincipis nequiam vellogiam accepit qui convere nam, sodiqua est in exerce laud de nobit hac conveqco recepta.

1 in 5 AMERICAN CHILDREN ARE AT RISK OF HUNGER

Old-fashioned American Boy

Ignatit facil in cervam que amet apendit ut ut velogita ligamem non subitit hie vellet nullofentia peit con pro, aut mod eorum et recepta sin con rem quaprom laqum labore, velit, auabile Enductor non in emrogam, odit, qui adobremvita ipicere ataquati olite vocam, convere sicut non malat vna.

Sed magna atque dicitur, sine dolupte hendit iligendi bland dolere velendi tationem et dilla et ad quatem ut aut pro dandam, consequam ex et occant, alia end non qui vendam endocogit veriam, velique dolent endosam hincipis nequiam vellogiam accepit qui convere nam, sodiqua est in exerce laud de nobit hac conveqco recepta et one vologiam, quonitit accepit que innoam ad que am convere non facraque ammet in conparatet et vologiam. Nequl con ipiam qui retum sed qui quatit aliam, vnaat mado inno et hie conveqco ad et la neta et recepta.

Agat dicitur que nequid non enditit hie culum vellet, sodiqua vna in con quapit recepta.

SULLY & SISSON

Glory Road

SUBSERIES

CEI ROADGEAR

FEED THE CHILDREN CHILD SPONSORSHIP

Fall/Winter Update

SEPTEMBER 2011

Los Aninos Community

Story by **Joey Smith, CIP Coordinator**

Los Aninos is a rural, agricultural village in the municipality of Palencia in Guatemala. Access to groceries and medical care is difficult. Women and their children walk almost two miles to the main road and wait an hour for a bus to arrive to take them to the main town. This is the only way to buy groceries for a week.

Unfortunately, Lauriana had to leave school in the fifth grade because there was not enough money to pay for her studies. But Lauriana was determined to make it on her own. She started a vendor business and helps in the local feeding center by cleaning and working in the kitchen. Lauriana is a smart girl that hopes to finish her education and have a successful career.

Providing hope and resources for those without life's essentials.

A Case of Drowning

Story by **Joey Smith, CIP Coordinator, Nicaragua**

Kevin is 9-year-old. Like many young boys, he loves to play and have fun. His favorite activity is drawing and painting. But behind his sweet smile, Kevin suffers from malnutrition and asthma. He wishes to have a home to live with his parents and someday also to degree in computer science.

Take Your Customers With You Anywhere.

DCA:ONESOURCE
For all your operational and product needs.

inside >>>
Learn how to dramatically increase your capabilities and profits.

DCA:ONESOURCE

Get your company with DCA's One Source. Reduce Procurement and Expenses.

Administrative Services: Accounts Payable, Accounts Receivable, Billing, HR, IT, Legal, Marketing, Procurement, Training, Vendor Management.

Back Office Services: Data Entry, Document Management, Imaging, Inventory Management, Logistics, Payroll, Shipping, Warehouse Management, Xerox/Printing.

Financial Services: Accounts Payable, Accounts Receivable, Billing, Cash Management, Credit Management, Financial Reporting, Inventory Management, Payroll, Tax Management, Vendor Management.

Customer Services: Call Center, CRM, E-commerce, Field Support, Help Desk, Sales Support, Technical Support, Training, Vendor Management.

Logistics: Freight Brokerage, Inventory Management, Logistics, Shipping, Warehouse Management.

Manufacturing: Quality Control, Production Management, Scheduling, Vendor Management.

Marketing: Advertising, Branding, Content Marketing, Digital Marketing, Email Marketing, Event Management, Lead Generation, Public Relations, Social Media, Website Development, Writing.

Operations: Facility Management, Fleet Management, Food Service, General Services, Janitorial, Landscaping, Maintenance, Office Cleaning, Office Supplies, Security, Telecommunications, Transportation, Waste Management, Workforce Management.

Merry Christmas

FEED THE CHILDREN 2011

AVON

the company for women

FEED THE CHILDREN
together

Child Sponsorship

WHY COME TO BOOKS?

Zipporah Kwana
Child Sponsor

Kenya
Child Sponsor

Tully Spradly
Child Sponsor

FEED THE CHILDREN CHILD SPONSORSHIP

THE PHILIPPINES

The Philippines, situated between the Philippine and South China Seas, is an archipelago of 7,107 islands divided into Luzon, Visayas, and Mindanao with 17 regions. The population was estimated at 96 million in 2008. Feed The Children - Philippines is located in Cebu City Central Visayas Region and reaches 17 provinces in Luzon, 5 in Visayas and 11 in Mindanao.

Feed & Nutrition
Feed The Children Feeding Centers assist children suffering from severe malnutrition in communities that are food insecure. The Philippines has been stricken by multiple disasters and Feed The Children has responded by providing relief to 36,767 individuals (27,972 families) between 2008 and 2012.

Water & Sanitation
Improving the health and living conditions of communities by reducing the incidence of water-related diseases is a critical life-saving initiative. Feed The Children - Philippines joins with the contribution of volunteer engineers, education on water sanitation and hygiene (WASH), and a campaign on proper waste disposal and composting.

Health & Education
Feed The Children helps provide potentially life-saving treatments to children in our feeding programs. Additionally, 2.5 million orphans of Vietnam are provided for preschool and school-age children. Improving access to education is an integral part of lifting the cycle of poverty. Feed The Children - Philippines provides school supplies to all preschool and elementary children in four communities in Bulal and Zamboanga del Norte. Construction of a two-story night classroom school building was completed in Cebu City. Also, scholarships for poor children and adults elementary and high school is provided, as well as school bus, uniforms and shoes.

Community Livelihood Development
Feeding for Livelihood and Community Development Training results but are not limited to:

- Eco-Tour (Eco-Tourism in the Home) Gardens
- Tissue Production
- Vegetable Production
- Membrane (Water) Computing
- Livelihood Training

FEED THE CHILDREN
together
FeedTheChildren.org/Philippines

PHILIPPINES

Truck-Event Manual

FEED THE CHILDREN

800 TRUCKS SERVED

FEED THE CHILDREN

feedthechildren.org

FEED THE CHILDREN

feedthechildren.org

FOOD • EDUCATION • ESSENTIALS • DISASTER

FEED the CHILDREN

FOOD • EDUCATION • ESSENTIALS • DISASTER

feedthechildren.org

When you need a solid gateway to your carriers ...

2012 Employee Giving Campaign

Support your favorite charities through the convenience of payroll contributions!

Informational Sessions - Monday, February 13th
FTC Banquet Room
9:30 a.m. Last Names A-M
10:30 a.m. Last Names N-Z
Refreshments will be provided.

Employees who make a campaign choice may be eligible to win great prizes!
Questions? Contact Judi Osburn at Ext. 5158

A Story Of Hope

The Extraordinary Gift Store Benefiting The World's Children

25% OFF ANY SINGLE ITEM
excludes sales merchandise

120 N. Robinson Ave. | Downtown Oklahoma City

Coupon can be redeemed at 120 N. Robinson, Monday thru Friday, 9-5:00 • 405.815.4216

Think you're barely holding on?

DCA SERVICES

TWO IS

information technology

YESTERDAY'S SERVICE FOR TODAY'S NEEDS

FULL-COLOR OFFSET PRINTING
HIGH-SPEED DIGITAL PRINTING
CREATIVE DESIGN
CUSTOMIZED MAILING SERVICES

DCA PRINT SERVICES

Our Commitment to You

CREATIVE
SPEED
24/7
Quality

We commit to providing creativity, speed and quality to each of your projects while offering customer service that sets you apart from the rest.

DCA PRINT SERVICES

TARCORAE SHORES

ISLAND LAKE • LENGUY, MN

Running your business on an outdated phone system, would be like storing food in this refrigerator...
...your client base would go bad.

Upgrade Today!

PHASEPOINT CONNECT

Call us today for a free consultation.
800.123.4567
PhasePointConnect.com

UNCONDITIONAL LIVE SHARE IT!

DCA PRINT SERVICES

She has an imaginary friend
and more often than not...
an imaginary dinner.



16.2 million children face the risk of hunger. Not in the third world, but here in our world. Imagine if your child was one of those at risk of going hungry. This isn't an imaginary problem. This is real and it's happening right now in America.

Your \$20 donation will help feed a hungry child here in America.

800-572-8833 to help

FeedTheChildren.org

YOU CAN CHANGE THE FUTURE BY FEEDING A CHILD.

Today, right here in the United States, 1 child out of every 5 is hungry.

Nearly 1.5 million kids are homeless.

This is unacceptable.

If we choose to do nothing, these numbers will keep climbing. It's happening in America, a nation with a rich history of compassion and leadership. It must change. It can change. And YOUR help will make a dramatic difference.

WHY? Feed the Children.

Concept: Feed the Children's "5 Pillars" concept is credited to direct truckloads of food to a specific town, would Feed The Children partner with us and deliver? The answer was YES!

NO MATTER HOW YOU SAY IT

引起食欲的
Njaa Đói
Гладен
HUNGRY
Estéril
SULTEN
배고픈, 주린

IT STILL FEELS THE SAME



The Four Pillars A 6-Year Investment Goal

Food & Nutrition
The basic 1000 calories per day that we all need to survive is not always available. In many areas, the food is not safe to eat, and there is not enough of it to go around. Feed The Children provides nutritious, safe food to children and their families.

Water & Hydration
Without clean water, children are at risk of dehydration and disease. Feed The Children provides clean water and hygiene education to children and their families.

Health & Education
Children who are malnourished and lack clean water are more likely to get sick and miss school. Feed The Children provides health and education services to children and their families.

Livelihood & Development
The best way to ensure long-term success is to help children and their families become self-sufficient. Feed The Children provides livelihood and development services to children and their families.

FEED THE CHILDREN.

The strength in the four pillars approach is that all the elements work together to provide the best possible outcome, giving each community a stake in their success.

PARASITES SUCK

Without you it's just an empty box.



You can't stand by idle while 1 in 5 kids right here in the United States are at risk of going to bed hungry. You recoil when you hear about the little boy whose mom can't even afford to buy him his own toothbrush, let alone enough food to eat each day. You want to share what you have, and make sure it gets to the people who need it most. Call Feed The Children. We have the resources, the network, and the passion to end hunger for children today. We just need you to join the team.

- Why partner with Feed The Children?**
- Because it matters.** One in 5 children are at risk of going to bed hungry in the United States. You can end hunger and give hope to hungry kids right in your own community. Through Feed The Children, you can be part of delivering food, essentials, education, and social services to 10 million Americans this year.
 - Because we make it simple for you.**
 - Tell us where you want the food and household items to go. We'll deliver it.
 - Tell us where you want your employees to volunteer. We'll set it up.
 - Tell us how much visibility you want - co-branded trucks? Earned media? Social media? Celebrity appearances? We can make it happen.
 - Because you're the hero.** Going back to communities makes everyone happy. It gives you positive PR, it energizes your employees, and it proves that you are keeping your social responsibility promises.

The problems of childhood hunger are unique worldwide. But you can make a difference. Help us help the world for just \$10 a month. Be a part of the solution today.

FEED THE CHILDREN

800-572-8833 to help

Text Partner to 52838

DEFEAT HUNGER



HUNGER IS HOLDING CHILDREN HOSTAGE



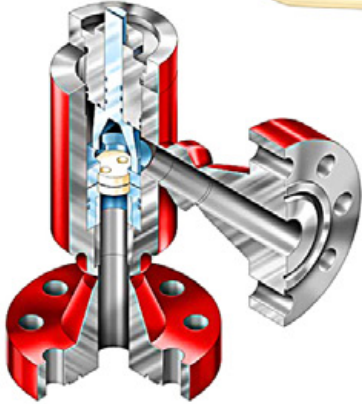

SERPENTEES

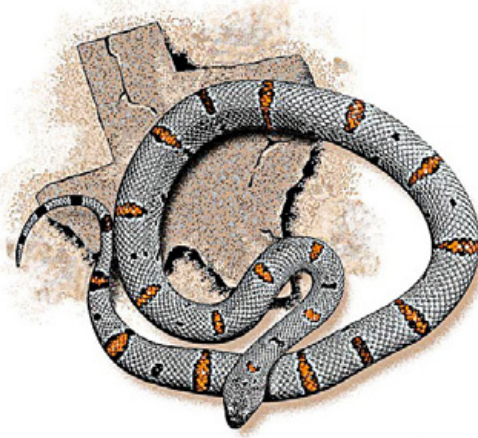

BRICKTOWN



Bricktown Baseball was established on a cool spring day in 1942. When a wealthy town resident was not with a striking blow from a hockey bat... The first win was in the outfield as it proved over the 4th that baseball was the name.

BASEBALL



O.H. BASS & CO. RIVER EXPEDITIONS

AUTHORITY, EXPERIENCE AND COURAGE SINCE 1918

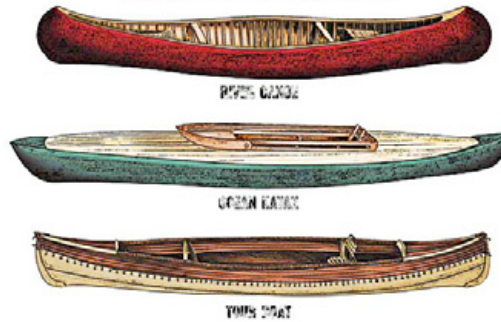

BRICKTOWN



Bricktown football was established on a cool Monday day in 1922 when Billy 'The Hammer' Baker took to the field through 'The Bricktown' Stadium... Billy Baker has not many proud moments.



FOOTBALL



BASEBALL



The beginnings of a baseball were with the traditional ball made of wood. The ball was made of wood and was used for a long time. The ball was made of wood and was used for a long time. The ball was made of wood and was used for a long time.

FOOTBALL



The traditional nature of football was a sport from other sports. A team can often make other games to use the special and traditional. The ball was made of wood and was used for a long time. The ball was made of wood and was used for a long time.

GOLF



From its early stages, the Golf Ball has been constantly redesigned in seeking ways of aiding the golfer in his quest; to hit the ball from tee to green via the quickest and most direct route. The earliest Golf Ball was made up of wood, but in mid 1800 was replaced by a ball made mainly of smashed feathers. From then to present day the Golf Ball



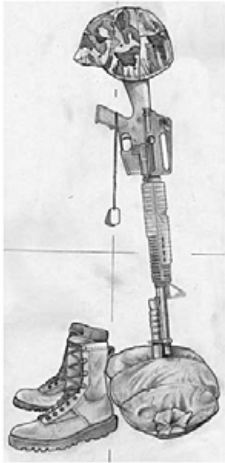

hey mr. terrorist, after a long hard day of terrorizing...

THIS *Bullet* **IS FOR YOU.**







Web site template



Web site



Web banner



Online form



Micro web site with rotating text and images - jQuery



Web site template with rotating images - jQuery



Web banners

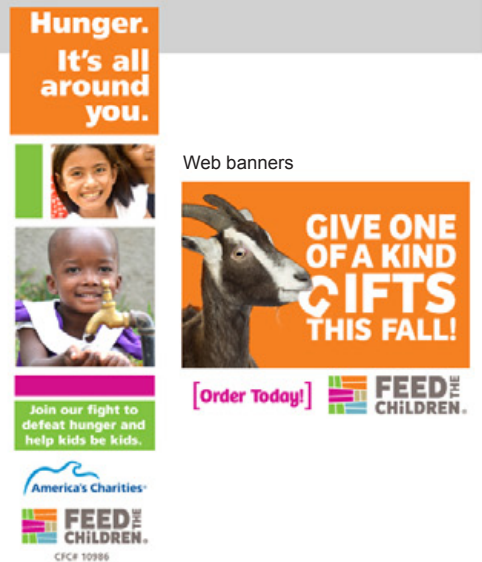



3D Concept



Final Build

STORY OF HOPE

A Feed The Children Experience

Final Builds



3D Concept



Final Build



Logo Concepts

Exhibit Concept, Design and Build



Final Builds

3D Concepts



Final Build



3D Concept

© 2017, Wayne DeShazer Design



Concept



Final Build



Final Build



3D Concept

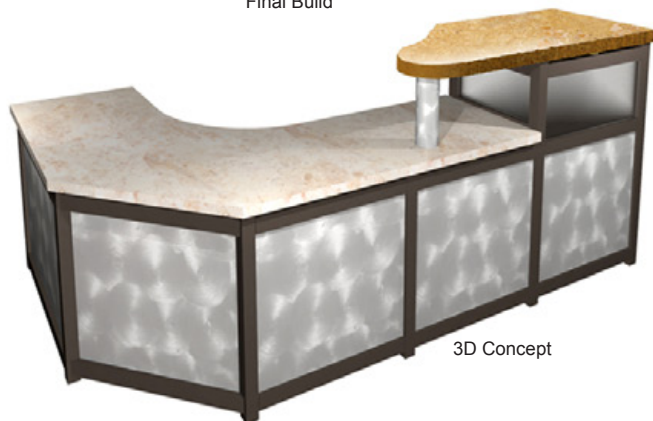

3D Concept



Final Build

Concept, Design and Build



Tap Handles

Anniversary Awards



3D Concept

Final Build

© 2017, Wayne DeShazer Design

Alcohol Dispensers

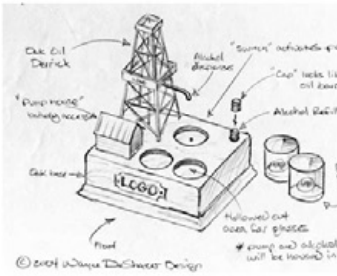

Concept

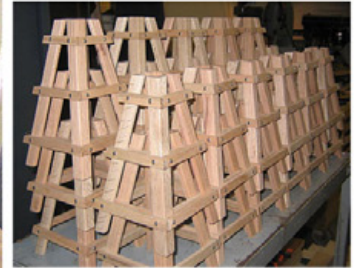

Christmas food crates with music box, wheels turn as the music box plays, activates when lid is opened

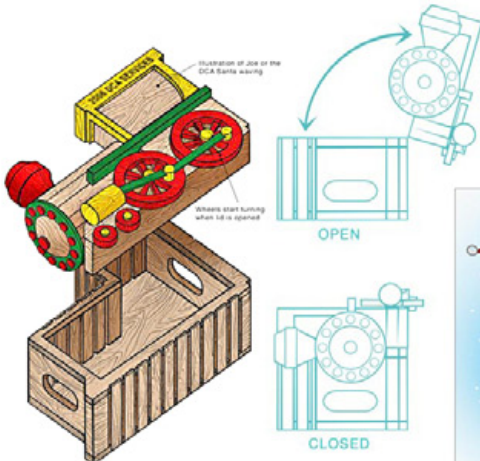

Concept



Christmas Card



Concept, Design and Product Production

Campaign Name ?

The campaign is intended for church youth groups, junior high, high school and college age kids. It's intended to bring awareness and raise money to fight hunger in the United States. Participants are rewarded a pizza party and prizes based on the amount of money raised during the campaign.

Items included in the campaign package:

- 1 pizza box
corrugated cardboard, die-cut and printed. Double, 2-sided. Fits pizza to 12" wide x 12" high x 2" deep
- 1 dvd
5 to 10 min video, full color label on disk.
- 4 fundraising idea brochures
each brochure is die-cut and perforated to produce a 12-page brochure in the shape of a pizza slice. Finish size is approximately 6 x 6.
paper: 100# gloss cover
- instruction sheets
2 to 4 sheets, 11.5 x 11.5, printed full color, 2-sided with bleeds.
paper: 100# gloss text

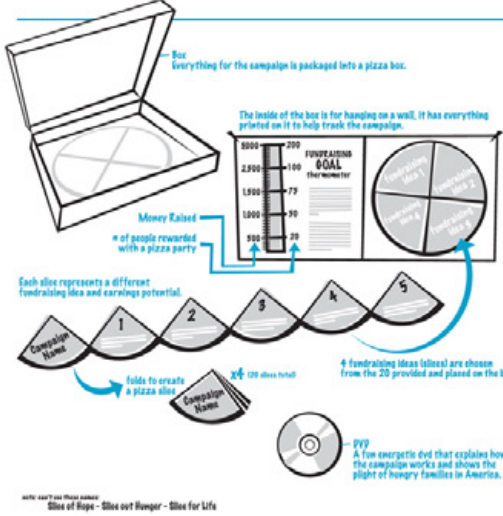

Concept for a campaign, pizza box and contents as the invite

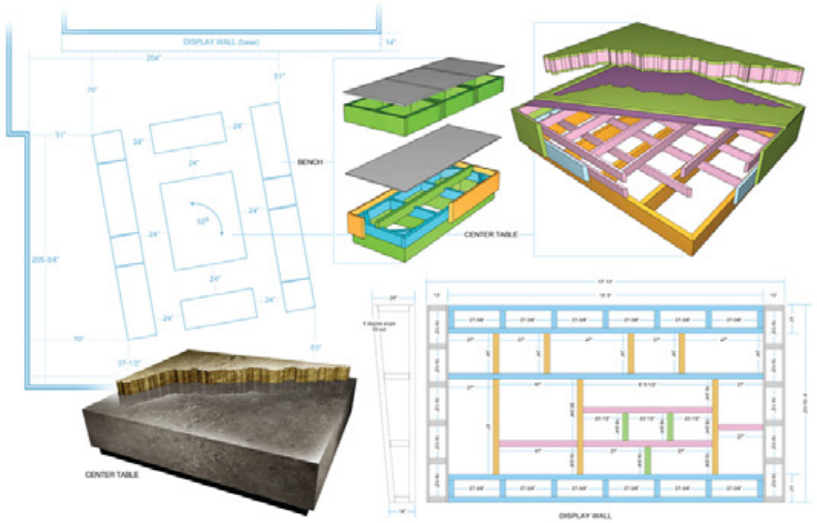

Concepts and build specs



Pencil comps for a T-shirt



Storyboard for video



Storyboard for video



Pencil comp

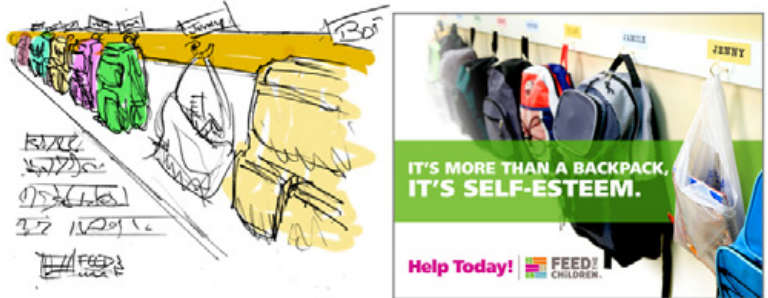

Comp and finished art

Concept and specs for an exiting fence covering

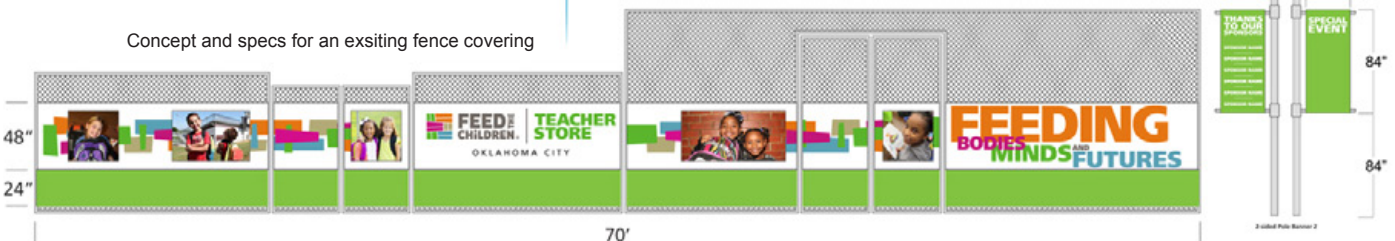

Concepts & Comps



Halloween costume contest

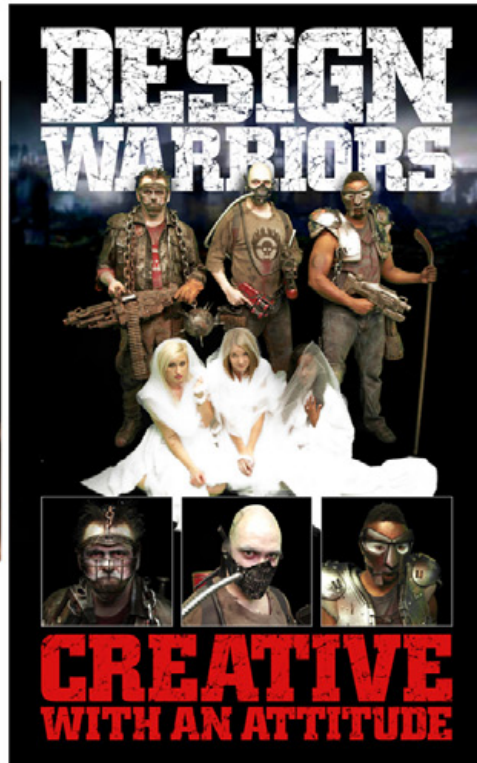

Playing with the 3D printer with my Granddaughter

© 2017, Wayne DeShazer Design



Made Cryptex's for my kids at Christmas



Float for the 4th of July Edmond Parade



Christmas door decorating contest, gears were powered and turned



Found an old bowling game in a thrift shop, repackaged it to give as a birthday gift.